

License to store building materials on the highway Frequently Asked Questions

If you are considering storing building materials such as bricks, or bags of sand on the carriageway, a **materials license** application must be submitted prior to when it is required. It is an offence to place anything on the highway without permission from the local Highways Authority (Highways Act 1980, section 169). Any materials stored without a license is illegal, and may be removed and result in legal action taken. If you wish to store materials on your private driveway you will not require a license.

We aim to satisfy the following principles by licensing materials stored on the highway:

- To permit materials to be placed on the highway where practicable
- To minimise the risk to other highway users
- To minimise obstruction to pedestrians and traffic
- To minimise the environmental impact of the use of the stored materials
- To minimise the risk of damage to the carriageway
- To recover the costs of any damage caused
- To protect the public interest

License conditions

If you want to place building materials on the road please observe the following conditions:

- The materials must be licensed before they are required to be placed on the road
- The materials must be properly fenced and protected, and lit overnight (to the standard the Council requires)
- The materials must be left in a tidy condition and not extended beyond 1 metre from the kerb line, or stored higher than 1 metre.
- Channels and gullies must be kept clear to allow the free flow of surface water
- Alternative pedestrian access and signage must be provided where footway access is limited
- No mixing or depositing of mortar on the highway
- Sites are inspected before the license is issued, during the license period, and after the license has expired to ensure materials have been removed and no damage has been caused to the highway.

- Please note that building materials cannot be stored on double yellow lines. In the event of this situation arising, an alternative location in a side road may be considered.
- We reserve the right to request the materials be removed at any time where safety to highway users is in question.

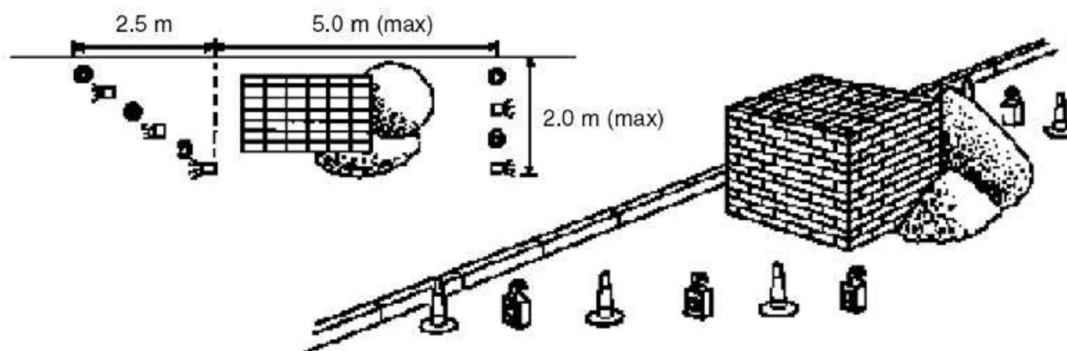

Licenses in these locations are valid for 28 days at a time.

License	Fee	Days
License	£27.00	28 Days

How to apply for a Materials License

If you are the resident or owner of a property and require a materials license please complete the building Materials License Application form.

We require 5 working days to consider and process a license application or renewal application.

Prior to a license being approved a site meeting may be arranged by the highways officer with the resident. The site may be inspected for any prior damage and any additional conditions are agreed onsite. The site is also inspected throughout the license period for safety and compliance with license conditions. A final site inspection is carried out at the end of the license period, once the materials have been removed, to establish if there is any damage to the highway.

Materials must not be placed onsite before inspection has taken place and before the license has been issued.