



MERTHYR TYDFIL
County Borough Council
Cyngor Bwrdeistref Sirol
MERTHYR TUDFUL

APPLICATION FOR PERMISSION TO DEPOSIT BUILDING MATERIALS ON THE PUBLIC HIGHWAY
Highways Act 1980 Section 171

Applicants Name:
Address:
.....
..... Post Code:
Daytime Telephone No:..... Email:.....

I wish to apply for permission to deposit building materials on the public highway at:
Site Address:.....
.....
..... Post Code:.....
Location of materials if not placed outside the site address:.....
.....

For this location state (in metres): *Delete as applicable
Width of footway:m
Width of verge (if any):m
Width of carriageway:m
Is it a bus route? Yes/No *
Is it a pedestrianised street? Yes/No *

State proposed Area Dimensions of Building Materials to be deposited (in metres):
Length:m
Width:m
Height:m

State the measures intended for traffic and pedestrian safety (cones, barriers etc):

State reasons why the materials can not be placed on private land:

The materials will be on the public highway from: to: inclusive.

Please note a licence can only be issued for a maximum of 28 days at any one time.

Please attach to this application:

A copy of your Public Liability Insurance. (A minimum of £5 million is required in respect of any one incident to cover liability against all third party risks)

A cheque for the correct fee made payable to 'Merthyr Tydfil County Council'.

I have read, and agree to comply with, the conditions overleaf.

Name (please print).....

Signed..... Date.....

Please return your completed application form with payment to your local Highway Area Office.

Checklist:

- *Have you read the guidance notes and conditions of licence?*
- *Have all sections been completed?*
- *Have you signed the application form?*
- *Have you provided the correct fee?*
- *Have you provided a copy of the planning approval number or proof that planning permission is not required?*
- *Have you provided a copy of your public liability insurance?*

Highway Area Office: Location Map and Contact Details

Permission to Deposit Building Materials on the Public Highway Highways Act 1980 Section 171

Terms and Conditions

1. All materials must be positioned so as not to obstruct other premises in the locality, impede the surface water drainage nor obstruct access to fire hydrants, highway drainage gullies, manholes and apparatus of any public utility. Nor must they be placed in such a location as to contravene any Traffic Regulation Order.
2. All materials shall be placed and stored in a safe manner so as not to cause a danger or nuisance to other users of the highway. The materials shall be positioned as to be clearly visible to traffic approaching from any direction at a distance of not less than 75m and shall not be positioned within 10m of a road junction. The materials shall be positioned so as to avoid undue obstruction and interference with users of the highway and at least 1.2m clear footway for the passage of pedestrians shall be maintained at all times. If this minimum clearance on the footway cannot be maintained, a portion of the carriageway must be fenced off for protection. Such fencing/barriers will need to be approved by the Highway Authority and may be subject to further conditions.
3. During the hours of darkness (between half an hour after sunset and half an hour before sunrise) the materials shall be illuminated by means of amber road danger lamps. Such illumination shall be provided to define the extent of any obstruction of the public highway. The lighting requirements will differ with each application and the applicant's proposals for such may be required by the Highway Authority prior to granting a licence. As a minimum requirement, lamps shall be positioned at the extreme corners of the material. Any lamps used shall be steady and positioned in such a manner as to not cause a nuisance to pedestrians or vehicular traffic.
4. All materials shall be signed and guarded at all times, in accordance with the requirements described in Chapter 8 of the Traffic Sign Manual, or the Safety At Street Works and Road Works 'A Code Of Practice'. The Highway Authority may require signing and guarding proposals prior to the approval of a licence application.

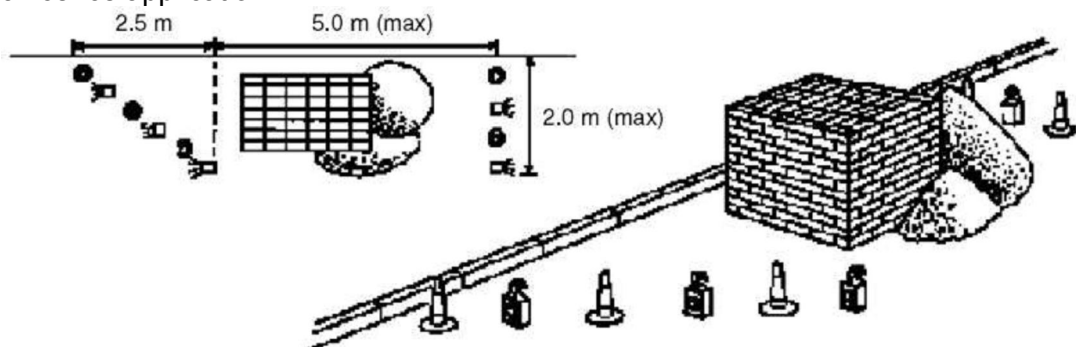

5. Except where agreed as part of this licence no part of the highway may be closed, without the consent of the Highway Authority.
6. No materials deposited on the highway shall contain any flammable, explosive, noxious or dangerous material, or any material which is likely to putrefy or otherwise become a nuisance or danger to users of the highway.
7. The County Council do not normally permit extensions to building materials licences. We will only consider allowing an extension to an existing licence under extenuating circumstances. Any request for an extension to the period for which the licence has been granted must be made to the Highway Authority at least three working days (excluding Saturday, Sunday and Bank Holidays) prior to the expiry of the licence.
8. The depositor shall continue in force without any amendment during the period of this permission a policy of Public Liability Insurance providing adequate cover against all risks attendant upon the deposit of material on the highway in accordance with this permission, which policy was approved by the Highway Authority prior to the granting of this permission. The Indemnity Limit for the Approved Policy shall be a minimum of £5 million.
9. On the expiry of the licence the public highway where the materials were deposited shall be left in a clean and tidy condition and any damage to the public highway shall be repaired by the Highway Authority at the expense of the licence holder.
10. The Highway Authority reserves the right to carry out inspections at any time so as to ensure compliance with those conditions specified. If we have to contact the owner regarding non-compliance of the permit an additional charge will be levied.
11. Nothing in this licence absolves the holder from their responsibilities to maintain access or provide protection to apparatus owned, used or maintained by Statutory Undertakers.
12. The Highway Authority may require the materials to be removed prior to the expiry of the licence in certain circumstances.

Important Notes

- For the purpose of this licence 'The Highway' shall include the carriageway, footway, back street and any verge.
- The granting of this licence does **not** permit the mixing of any mortar, concrete or cement on the highway or any other materials which may permanently stain or disfigure the highway.